

# Q & A

Q

A

2002 11 15 가

1

58dB

50dB 가

가 1% 가

가

110cm 120cm  
15cm 10cm

100

150

15m<sup>2</sup>

20m<sup>2</sup>

Q

A

가 ?

가

가

가

가

가

가

:

:

가

가

가

가

Q

A

T

(Z , )

( )

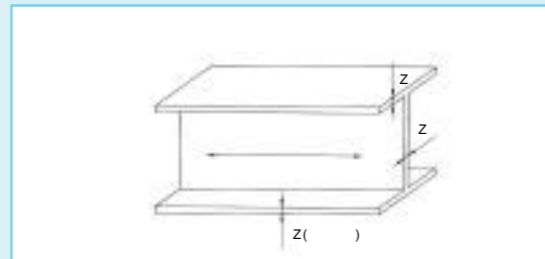
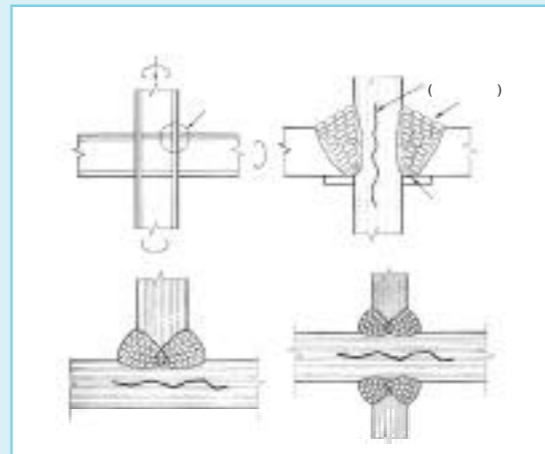

(Z )

(MnS, MnSi)

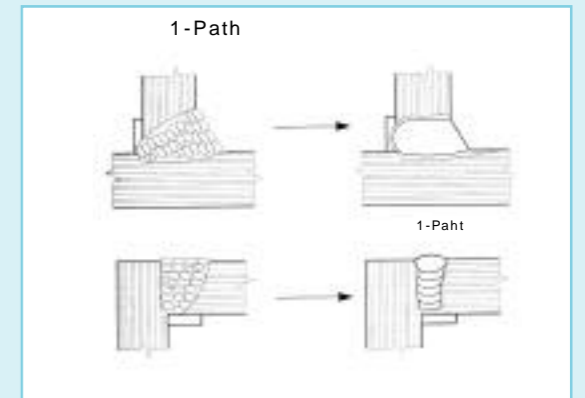
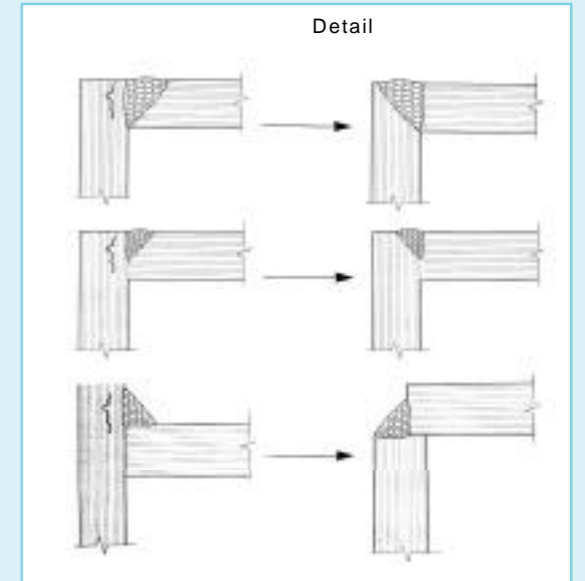

(Narrow Gap Welding)